

**SAW AND SEAL**  
 ( Random Crack > 1/2" Width )

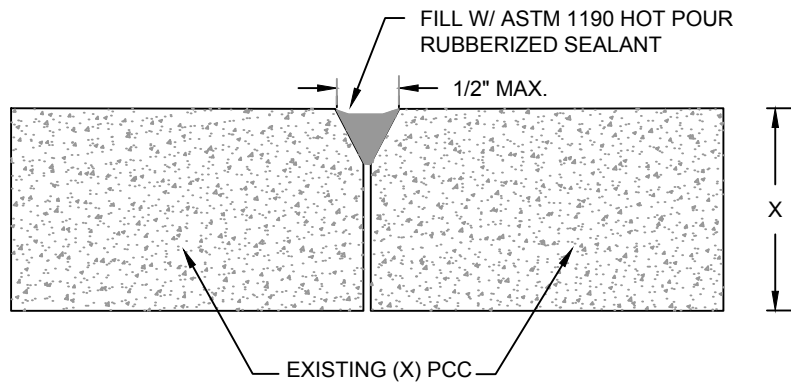

**JOINT AND RANDOM CRACK**  
 ( 1/2" Wide or Less )

METHOD REQUIRED WILL BE MARKED BY THE ENGINEER

CITY OF WATFORD CITY, NORTH DAKOTA PUBLIC WORKS DEPARTMENT	
CONCRETE JOINTS	
APPROVED FOR PUBLICATION	DWG. NO.
_____ City Engineer	_____ Date
	500-1