

- NOTE NO.1 - MANHOLE CASTING AND COVER SHALL BE AS DEFINED IN SECTION 1205-2.5.
- NOTE NO.2 - ALLOWANCE FOR ADJUSTMENT - 0" TO 6" - SEE STANDARD DETAIL NO. 1206-1.
- NOTE NO.3 - CRETEX P2 GASKETED JOINT FOR 48" MANHOLES, CRETEX CX-4 JOINT FOR ALL OTHER SIZES OF MANHOLES OR EXTERIOR SEAL BY PRESS-SEAL GASKET CORP. EZ WRAP AND EZ STIK NO. 4 PRIMER, CRETEX SPECIALTY PRODUCTS "MAC WRAP", OR AN APPROVED EQUAL.
- NOTE NO.4 - IF PRECAST MANHOLE BASE IS USED, FLOOR SHALL BE GROUTED AND SLOPED, AS SHOWN, FROM 1/2 THE DIAMETER OF THE PIPE. SEE SECTION 1205-2.9 FOR PRECAST MANHOLE BASE REINFORCEMENT.
- NOTE NO.5 - MANHOLE TOP SECTION SHALL BE ECCENTRIC FOR 48" MANHOLES.
- NOTE NO.6 - CAST IN PLACE MANHOLE BASES SHALL BE DIMENSIONED AS SHOWN UNLESS OTHERWISE INDICATED. BASES SHALL BE REINFORCED WITH NO.4 REBAR SPACED 15" ON CENTER BOTH WAYS.
- NOTE NO.7 - ENCASE PIPE AND ELBOW IN CONCRETE. CONCRETE SHALL BE NOT LESS THAN 6" THICK, MEASURED FROM THE OUTSIDE WALL OF THE PIPE.
- NOTE NO.8 - EXTERNAL MANHOLE CHIMNEY SEAL AS MANUFACTURED BY CRETEX OR AN APPROVED EQUAL, IF SPECIFIED.
- NOTE NO.9 - STEPS SHALL BE PLACED IN SANITARY SEWER, STORM SEWER AND AIR RELEASE MANHOLES AND INLETS AS SPECIFIED. THE MANHOLE STEPS SHALL BE DELTA SUREFOOT OR APPROVED EQUAL. STEPS SHALL BE SPACED 16" ON CENTER.

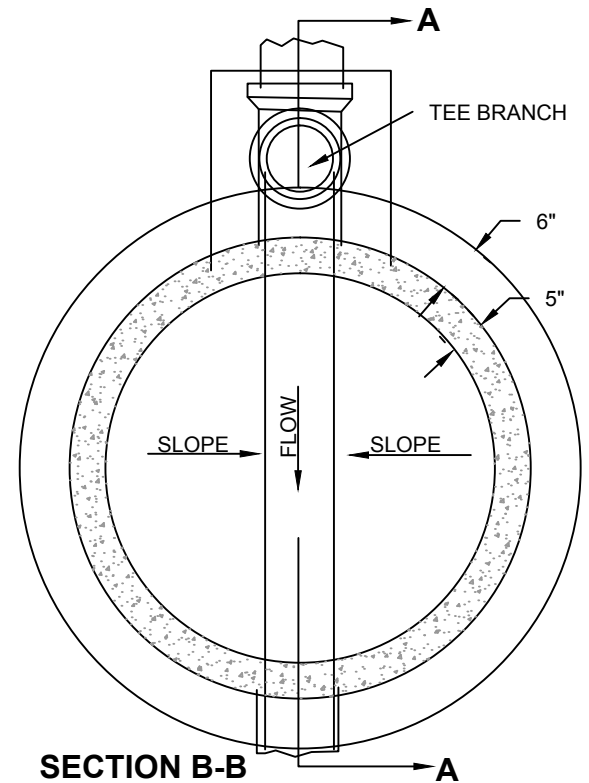
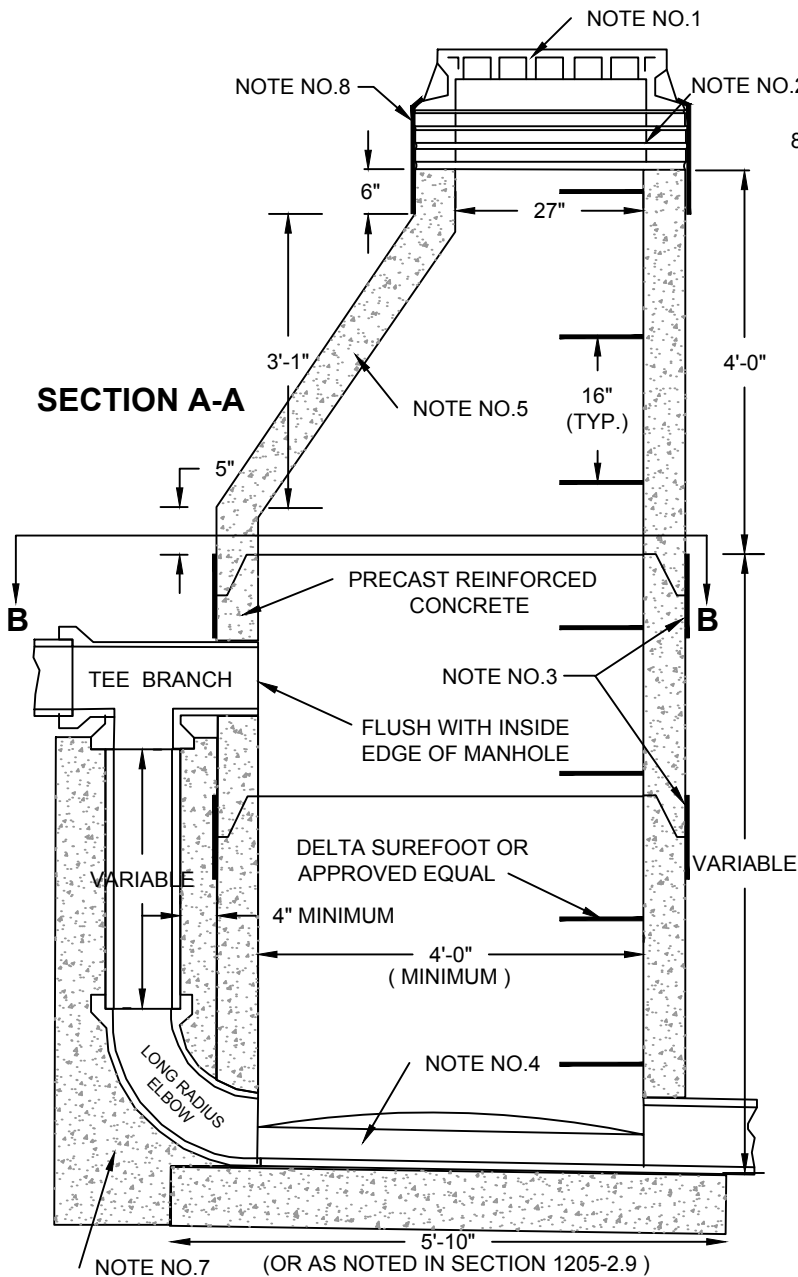
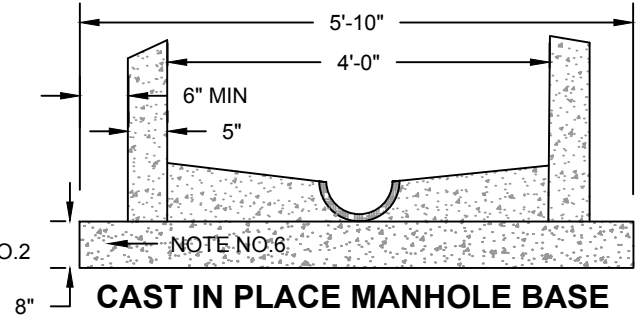

CITY OF WATFORD CITY, NORTH DAKOTA PUBLIC WORKS DEPARTMENT	
SANITARY SEWER DROP MANHOLE	
APPROVED FOR PUBLICATION	DWG. NO.
_____ City Engineer	_____ Date
1205-2	